

SPECIFICATIONS

HX260L

Tier 4 Final Engine

Net Power SAE J1349 / 179 HP (133 kW) at 1,950 rpm)	Bucket Range 1.41yd ³ - 1.96yd ³ Standard Bucket 1.41 yd ³	Operating Weight 25,600 kg / 56,440 lbs
--	--	---

ENGINE

Maker / Model	Cummins QSB6.7		
Type	4-cycle turbocharged, charger air cooled, diesel engine		
Rated flywheel horse power	SAE	J1995 (gross)	190 HP (142 kW) at 1,950 rpm
		J1349 (net)	179 HP (133 kW) at 1,950 rpm
	DIN	6271/1 (gross)	193 PS (142 kW) at 1,950 rpm
		6271/1 (net)	181 PS (133 kW) at 1,950 rpm
Max. torque	82.5 kgf·m (597 lbf-ft) at 1500 rpm		
Bore X stroke	107x124 mm (4.21" x 4.88")		
Piston displacement	6700 cc (409in ³)		
Batteries	2x12Vx100 Ah		
Starting motor	Denso (24V-4.8 kW)		
Alternator	Denso (24V-95 A)		

HYDRAULIC SYSTEM

MAIN PUMP

Type	Variable displacement tandem axis piston pumps
Max. flow	2x228.2 lpm (60.3 gpm)
Sub-pump for pilot circuit	Gear pump

Cross-sensing and fuel saving pump system

HYDRAULIC MOTORS

Travel	Two speed axial pistons motor with brake valve and parking brake
Swing	Axial piston motor with automatic brake

RELIEF VALVE SETTING

Implement circuits	350 kgf/cm ² (4,980 psi)
Travel	350 kgf/cm ² (4,980 psi)
Power boost (boom, arm, bucket)	380 kgf/cm ² (5,400 psi)
Swing circuit	300 kgf/cm ² (4,270 psi)
Pilot circuit	40 kgf/cm ² (569 psi)
Service valve	Installed

HYDRAULIC CYLINDERS

No. of cylinder bore X stroke	Boom: Ø5.3x52.9 in
	Arm: Ø5.7x63.7 in
	Bucket: Ø5.1x46.7 in

DRIVES & BRAKES

Drive method	Fully hydrostatic type
Drive motor	Axial piston motor, in-shoe design
Reduction system	Planetary reduction gear
Max. drawbar pull	21,100 kgf (46,500 lbf)
Max. travel speed (high / low)	5.8 km/hr (3.60 mph) / 3.4 km/hr (2.11 mph)
Gradeability	35° (70%)
Parking brake	Multi wet disc brake

CONTROL

Pilot pressure operated joysticks and pedals with detachable lever for minimal operator fatigue.

Pilot control	Two joysticks with one safety lever (LH): Swing and arm, (RH): Boom and bucket (ISO)
Traveling and steering	Two levers with pedals
Engine throttle	Electric, Dial type

OPERATING WEIGHT (APPROXIMATE)

Operating weight, including 5,850mm (19' 2") boom, 3,050mm (10' 0") arm, SAE heaped 1.08m³ (1.41 yd³) bucket, lubricant, coolant, full fuel tank, full hydraulic tank, and all standard equipment.

OPERATING WEIGHT

Shoes		Operating weight		Ground pressure
Type	Width mm (in)	kg (lb)		kgf/cm ² (psi)
Triple grouser	600 (24")	HX260 L	25,600 (56,440)	0.52 (7.40)
	700 (28")	HX260 L	25,900 (57,100)	0.45 (6.40)
	800 (32")	HX260 L	26,200 (57,760)	0.40 (5.69)
	900 (36")	HX260 L	26,500 (58,420)	0.36 (5.12)



SWING SYSTEM

Swing motor	Fixed displacement axial piston motor
Swing reduction	Planetary gear reduction
Swing bearing lubrication	Grease-bathed
Swing brake	Multi wet disc brake
Swing speed	10.8 rpm

SERVICE REFILL CAPACITIES

Re-filling	liters	US gal
Fuel tank	400	106
Engine coolant	40	10.6
Engine oil	23	6.1
Swing device	7	1.85
Final drive (each)	4.5	1.19
Hydraulic system (including tank)	275	90.9
Hydraulic tank	160	41.25
DEF/AdBlue®	27	7.1

UNDERCARRIAGE

The X-leg type center frame is integrally welded with reinforced box-section track frames. The undercarriage includes lubricated rollers, idlers, track adjusters with shock absorbing springs and sprockets, and a track chain with double or triple grouser shoes.

Center frame	X - leg type
Track frame	Pentagonal box type
No. of shoes on each side	51 EA
No. of carrier roller on each side	2 EA
No. of track roller on each side	9 EA
No. of rail guard on each side	2 EA

SPECIFICATIONS HX260L

Tier 4 Final Engine

HX260L DIMENSIONS

5.85 m (19' 2") BOOM and 2.1 m (6' 11"), 2.5 m (8' 2"), 3.05 m (10' 0"), 3.6 m (11' 10") ARM

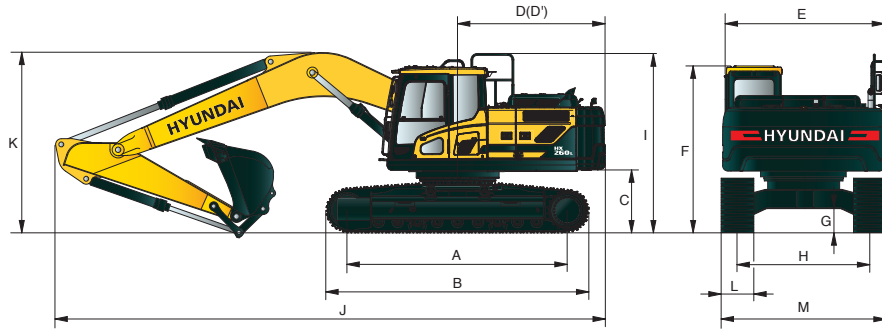

A	Tumbler distance	3,830 (12' 7")
B	Overall length of crawler	4,640 (15' 3")
C	Ground clearance of counterweight	1,110 (3' 6")
D	Tail swing radius	2,975 (9' 9")
D'	Rear-end length	2,870 (9' 5")
E	Overall width of upperstructure	2,840 (9' 4")
F	Overall height of cab	3,050 (10' 0")
G	Min. ground clearance	480 (1' 7")
H	Track gauge	2,580 (8' 6")
I	Overall height of guardrail	3,260 (10' 7")

Unit : mm (ft-in)

Boom length	5,850 (19' 2")			
Arm length	2,100 (6' 11")	2,500 (8' 2")	3,050 (10' 0")	3,600 (11' 10")
J Overall length	10,050 (33' 0")	10,000 (32' 10")	9,920 (32' 7")	9,910 (32' 6")
K Overall height of boom	3,530 (11' 7")	3,590 (11' 9")	3,220 (10' 7")	3,590 (11' 9")
L Track shoe width	600 (24")	700 (28")	800 (32")	900 (36")
M Overall width	3,180 (10' 5")	3,280 (10' 9")	3,380 (11' 1")	3,480 (11' 5")

HX260L WORKING RANGE

Unit : mm (ft-in)

Boom length	5,850 (19' 2")			
Arm length	2,100 (6' 11")	2,500 (8' 2")	3,050 (10' 0")	3,600 (11' 10")
A Max. digging reach	9,550 (31' 4")	9,870 (32' 5")	10,360 (34' 0")	10,870 (35' 8")
A' Max. digging reach on ground	9,360 (30' 9")	9,680 (31' 9")	10,190 (33' 5")	10,700 (35' 1")
B Max. digging depth	6,050 (19' 10")	6,450 (21' 2")	7,000 (23' 0")	7,550 (24' 9")
B' Max. digging depth (8' level)	5,840 (19' 2")	6,260 (20' 6")	6,830 (22' 5")	7,400 (24' 3")
C Max. vertical wall digging depth	5,480 (18' 0")	5,640 (18' 6")	6,150 (20' 2")	6,830 (22' 5")
D Max. digging height	9,450 (31' 0")	9,460 (31' 0")	9,670 (31' 9")	9,920 (32' 7")
E Max. dumping height	6,360 (20' 10")	6,420 (21' 1")	6,630 (21' 9")	6,860 (22' 6")
F Min. swing radius	4,420 (14' 6")	4,200 (13' 9")	3,980 (13' 1")	3,900 (12' 10")

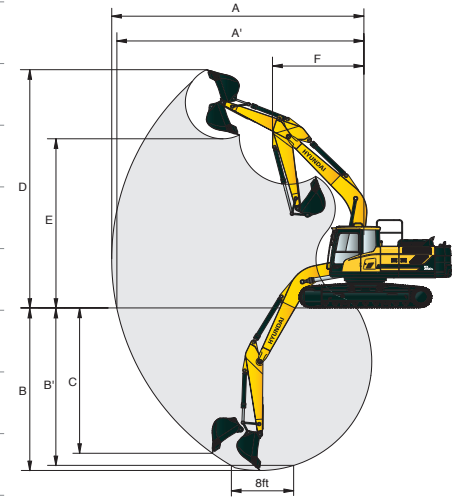

DIGGING FORCE

Boom	Length	mm (ft-in)	5,850 (19' 2")				Remark
	Weight	kg (lb)	2,460 (5,420)				
Arm	Length	mm (ft-in)	2,100 (6' 11")	2,500 (8' 2")	3,050 (10' 0")	3,600 (11' 10")	
	Weight	kg (lb)	1,420 (3,130)	1,450 (3,200)	1,540 (3,400)	1,600 (3,530)	
Bucket digging force	SAE	kN	156.9 [170.4]	156.9 [170.4]	156.9 [170.4]	156.9 [170.4]	
		kgf	16000 [17370]	16000 [17370]	16000 [17370]	16000 [17370]	
	lbf	35270 [38290]	35270 [38290]	35270 [38290]	35270 [38290]		
	ISO	kN	178.5 [193.8]	178.5 [193.8]	178.5 [193.8]	178.5 [193.8]	
kgf		18200 [19760]	18200 [19760]	18200 [19760]	18200 [19760]		
Arm crowd force	SAE	kN	134.4 [145.9]	130.4 [141.6]	114.7 [124.6]	104.0 [112.9]	[]: Power Boost
		kgf	13700 [14870]	13300 [14440]	11700 [12700]	10600 [11510]	
	lbf	30200 [32790]	29320 [31830]	25790 [28000]	23370 [25370]		
	ISO	kN	139.3 [151.2]	134.4 [145.9]	118.7 [128.8]	107.9 [117.1]	
		kgf	14200 [15420]	13700 [14870]	12100 [13140]	11000 [11940]	
		lbf	31310 [33990]	30200 [32790]	26680 [28970]	24250 [26330]	

Note : Boom weight includes arm cylinder, piping, and pin
Arm weight includes bucket cylinder, linkage, and pin

SPECIFICATIONS

HX260L

Tier 4 Final Engine

Rating over-front Rating over-side or 360 degree

HX260L LIFTING CAPACITY - 5.85 m (19' 2") boom equipped with 1.08 m³ (SAE heaped) bucket and 600 mm (24") triple grouser shoe

Load point height m (ft)	1.5 m (5 ft)		3.0 m (10 ft)				Load radius 4.5 m (15 ft)				6.0 m (20 ft)				7.5 m (25 ft)				At max. reach Capacity				Reach m (ft)						
	2.10 m (6' 11")	2.10 m (6' 11")	2.50 m (8' 2")	2.50 m (8' 2")	2.10 m (6' 11")	2.10 m (6' 11")	2.50 m (8' 2")	2.50 m (8' 2")	2.10 m (6' 11")	2.10 m (6' 11")	2.50 m (8' 2")	2.50 m (8' 2")	2.10 m (6' 11")	2.10 m (6' 11")	2.50 m (8' 2")	2.50 m (8' 2")	2.10 m (6' 11")	2.10 m (6' 11")	2.50 m (8' 2")	2.50 m (8' 2")	2.10 m (6' 11")	2.10 m (6' 11")	2.50 m (8' 2")	2.50 m (8' 2")	2.10 m (6' 11")	2.50 m (8' 2")			
6.0 m (20 ft)	kg																												
	lb																												
4.5 m (15 ft)	kg							*7730	*7730																				
	lb							*17040	*17040																				
3.0 m (10 ft)	kg																												
	lb																												
1.5 m (5 ft)	kg																												
	lb																												
Ground	kg																												
	lb																												
-1.5 m (-5 ft)	kg					*15540	15310	*15190	15040	*13000	7280	*13050	7200	7990	4590	7930	4540					5540	3190	5060	2970	4670	2710	8.13	8.49
	lb					*34260	33750	*33490	33160	*28660	16050	*28770	15870	17610	10120	17480	10010					12210	7030	11160	6550	10300	5970	(26.7)	(27.9)
-3.0 m (-10 ft)	kg			*16450	*16450	*17010	15630	*17960	15340	*12000	7440	*12340	7310	8100	4700	7990	4590												
	lb			*36270	*36270	*37500	34460	*39590	33820	*26460	16400	*27210	16120	17860	10360	17610	10120												
-4.5 m (-15 ft)	kg					*13270	*13270	*14720	*14720	*9380	7840	*10300	7630																
	lb					*29260	*29260	*32450	*32450	*20680	17280	*22710	16820																

Load point height m (ft)	1.5 m (5 ft)		3.0 m (10 ft)				Load radius 4.5 m (15 ft)				6.0 m (20 ft)				7.5 m (25 ft)				9.0 m (30 ft)				At max. reach Capacity				Reach m (ft)		
	3.05 m (10' 0")	3.05 m (10' 0")	3.60 m (11' 10")	3.60 m (11' 10")	3.05 m (10' 0")	3.05 m (10' 0")	3.60 m (11' 10")	3.60 m (11' 10")	3.05 m (10' 0")	3.05 m (10' 0")	3.60 m (11' 10")	3.60 m (11' 10")	3.05 m (10' 0")	3.05 m (10' 0")	3.60 m (11' 10")	3.60 m (11' 10")	3.05 m (10' 0")	3.05 m (10' 0")	3.60 m (11' 10")	3.60 m (11' 10")	3.05 m (10' 0")	3.05 m (10' 0")	3.60 m (11' 10")	3.60 m (11' 10")	3.05 m (10' 0")	3.05 m (10' 0")	3.60 m (11' 10")	3.60 m (11' 10")	3.05 m (10' 0")
6.0 m (20 ft)	kg																												
	lb																												
4.5 m (15 ft)	kg																												
	lb																												
3.0 m (10 ft)	kg																												
	lb																												
1.5 m (5 ft)	kg																												
	lb																												
Ground	kg																												
	lb																												
-1.5 m (-5 ft)	kg	*10030	*10030	*9120	*9120	*13960	*13960	*13310	*13310	*12950	7090	*12690	7020	7840	4450	7780	5370	5450	3100	5370	3020								
	lb	*22110	*22110	*20110	*20110	*30780	*30780	*29340	*29340	*28550	15630	*27980	15480	17280	9810	17150	11840	12020	6830	11840	6660								
-3.0 m (-10 ft)	kg	*13630	*13630	*12230	*12230	*18520	14940	*16930	14640	*12640	7120	*12750	6970	7830	4440	7710	5340												
	lb	*30050	*30050	*26960	*26960	*40830	32940	*37320	32280	*27870	15700	*28110	15370	17260	9790	17000	11770												
-4.5 m (-15 ft)	kg	*17920	*17920	*15940	*15940	*16430	15430	*17690	15030	*11230	7350	*11810	7120	*8010	4620	7820													
	lb	*39510	*39510	*35140	*35140	*36220	34020	*39000	33140	*24760	16200	*26040	15700	*17660	10190	17240													

- Lifting capacity are based on SAE J1097 and ISO 10567.
- Lifting capacity of the HX series does not exceed 75% of tipping load with the machine on firm, level ground or 87% of full hydraulic capacity.

- The load point is a hook located on the back of the bucket.
- (*) indicates load limited by hydraulic capacity.
- Additional lifting capacity charts are available upon request.

SPECIFICATIONS HX260L

Tier 4 Final Engine

ENGINE	STD	OPT
Cummins QSB 6.7 engine	●	
HYDRAULIC SYSTEM		
Intelligent Power Control (IPC)		
3-power mode, 2-work mode, user mode	●	
Variable Power Control	●	
Pump Flow Control	●	
Attachment Mode Flow Control	●	
Engine Auto Idle	●	
Engine Auto Shutdown Control		●
Electronic Fan Control	●	
CAB & INTERIOR		
ISO Standard cabin		
Rise-up type windshield wiper	●	
Radio / USB player	●	
Bluetooth / Handsfree mobile phone system with USB	●	
Miracast	●	
12 volt power outlet (24V DC to 12V DC converter)	●	
Electric horn	●	
All-weather steel cab with 360° visibility	●	
Safety glass windows	●	
Sliding fold-in front window	●	
Sliding side window (LH)	●	
Lockable door	●	
Hot & cool box	●	
Storage compartment & Ashtray	●	
Transparent cabin roof-cover	●	
Sun visor	●	
Door and cab locks, one key	●	
Mechanical suspension seat with heater	●	
Pilot-operated adjustable joystick	●	
Console box height adjust system	●	
Automatic climate control		
Air conditioner & heater	●	
Defroster	●	
Starting Aid (air grid heater) for cold weather	●	

Centralized monitoring		
8" LCD display	●	
Engine speed or Trip meter/Accel.	●	
Engine coolant temperature gauge	●	
Max power	●	
Low speed/High speed	●	
Auto idle	●	
Overload		●
Check Engine	●	
Air cleaner clogging	●	
Indicators	●	
ECO Gauges	●	
Fuel level gauge	●	
Hyd. oil temperature gauge	●	
Fuel warmer	●	
Warnings	●	
Communication error	●	
Low battery	●	
Clock	●	
Cabin lights	●	
Cabin front window rain guard		●
Cabin roof-steel cover		●
Seat		
Adjustable air suspension seat with heater	●	
Cabin FOPS/FOG		
FOPS (Falling Object Protective Structures) ISO 3449 Level 2		●
FOG (Falling Object Guard) Front & Top Guard		●
ISO/DIS 10262 Level 2 Top Guard		●
Cabin ROPS		
ROPS (Roll Over Protective Structures) ISO 12117-2	●	
SAFETY		
Battery master switch	●	
Rearview camera	●	
AAVM (All Around View Monitoring)		●
Four front working lights	●	
Dual boom working lights	●	
Travel alarm	●	
Rear work lamp		●
Beacon lamp		●
Automatic swing brake	●	
Boom holding system	●	
Arm holding system	●	
Safety lock valve for boom cylinder with overload warning device		●
Safety lock valve for arm cylinder		●
Swing Lock System		●
Three outside rearview mirrors	●	

OTHER	STD	OPT
Booms		
5.85 m, 19' 2"	●	
Arms		
2.1 m, 6' 11"		●
2.5 m, 8' 2"		●
3.05 m, 10' 0"	●	
3.60 m, 11' 10"		●
Removable clean-out dust net for cooler	●	
Removable reservoir tank	●	
Fuel pre-filter	●	
Fuel warmer		●
Self-diagnostics system	●	
Hi-mate (Remote Management System)	Mobile Satellite	●
Batteries (2 x 12V x 100 AH)	●	
Fuel filler pump (50 lpm / 13 gpm)		●
Single-acting piping kit (breaker, etc.)		●
Double-acting piping kit (clamshell, etc.)	●	
Rotating Piping Kit		●
Quick coupler piping		●
Quick coupler		●
Boom floating control		●
One Pedal Straight Travel System		●
Accumulator for lowering work equipment	●	
Pattern change valve (2 patterns)	●	
Fine Swing Control System		●
Tool kit		●
UNDERCARRIAGE		
Lower frame under cover (Additional)	●	
Lower frame under cover (Normal)	●	
Track shoes		
Triple grousers shoes (600 mm, 24")		●
Triple grousers shoe (700 mm, 28")		●
Triple grousers shoe (800 mm, 32")	●	
Triple grousers shoe (900 mm, 36")		●
Double grousers shoe (700 mm, 28")		●
Track rail guard	●	
Full track rail guard		●

* Standard and optional equipment may vary. Contact your Hyundai dealer for more information.

The machine may vary according to International standards.

* The photos may include attachments and optional equipment that are not available in your area.

* Materials and specifications are subject to change without advance notice.

* All imperial measurements rounded off to the nearest pound or inch.

PLEASE CONTACT



6100 ATLANTIC BOULEVARD NORCROSS GA 30071 U.S.A
TEL: (1) 678-823-7802 FAX: (1) 678-823-7778

www.hceamericas.com

HCEA Rev 7/2015