

We build a better future



■ Photo may include optional equipment

HYUNDAI LPG FORKLIFT TRUCKS - Applied Tier 4 Engine

**15/18/20L-7M**

 **HYUNDAI**  
HEAVY INDUSTRIES EUROPE



# NEW criterion of Forklift Trucks

Hyundai introduces a new line of 7M-series  
LPG forklift trucks.  
Excellent power and performance make your  
business more profitable.



## OPSS (Operator Presence Sensing System)

Control of mast tilting, lifting and lowering is not possible when the operator is not in the normal position.

■ Photo may include optional equipment

# The new master on your job-site!

Smooth running, efficient and ergonomically designed, 15L/18L/20L-7M series are made to meet your needs.

## 50PS / 2,450 rpm



### Powerful Engine L4KB Engine

Market approved quality of L4KB engine ensures incomparable performance, durability and additional value to the machine. Powerful and efficient engine provides excellent fuel consumption and excellent torque improved operator's comfort. (EPA/CARB Tier-IV Certified)

### Fast and stable performance

Being able to quickly raise and lower the mast, as well as tilting forward and backward, the truck provides you the best operational conditions during loading/unloading operations.

When the truck is fully loaded, mast lowering speed is carefully controlled to ensure safety by the down control valve.

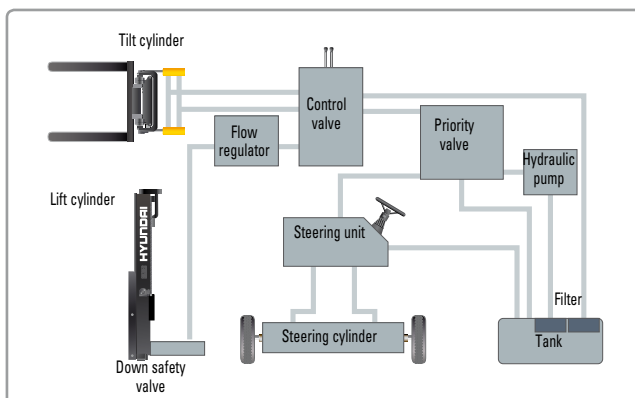

### State-of-the-art hydraulic system

The latest designed, large-capacity hydraulic system including a low-noise control valve shortens reaction time during operation and improves both efficiency and durability.



### Fully hydrostatic power steering

A hydraulic steering system always guarantees smooth and flexible steering, preventing overrun and steering wheel kick-back.



**High Power  
Low Noise**

■ Photo may include optional equipment



### Increased mast tilting angle

A mast tilting angle of 6 degrees forward and 10 degrees backward gives the operator a safe and rapid platform for loading and unloading jobs.

### Faster travel speed & better grade-ability

The powerful high-output engine provides greater acceleration, better grade-ability and faster travel speed on any tough terrain or slope.



### Grade-ability (Loaded)

15L-7M : 39.7°

18L-7M : 35.4°

20L-7M : 33.0°

### Travel speed (Unloaded)

15L-7M : 20.1 km/h

18L-7M : 20.1 km/h

20L-7M : 20.1 km/h

# Ergonomic operator friendly compartment design!

A design based on human engineering relieves fatigue and increases operator's efficiency.

## Operator friendly gauges and water-resistant monitor panel



- |   |                                    |                      |
|---|------------------------------------|----------------------|
| 1 Parking brake lamp                        | 6 Battery charging warning lamp    | 12 Fuel gauge        |
| 2 Directional indicators                    | 7 Air cleaner filter warning light | 13 Hour meter        |
| 3 Fuel warning lamp                         | 8 Working light indicator          | 14 Engine check lamp |
| 4 Engine oil warning lamp                   | 9 Water separator lamp             | 15 Seat belt warning |
| 5 Transmission oil temperature warning lamp | 10 Pre-heater indicator            | 16 DPSS warning      |
|   | 11 Water temperature gauge         |                      |



### Grammer Seat (Option)

- Quick Achievement of the Ergonomically Best Sitting Position
- Asymmetrical Backrest
- Movable Armrests - Seat Heating
- Practical Document Box



### High visibility for safe operation

The operator is able to work with increased safety and accuracy due to a wider view mast.



### Ergonomic positioned pedals

Based on human engineering, the accelerator, brake and inching pedals are optimally positioned for operator's convenience. Easy to remove cleanable rubber floor mat.



### Cup holder & console box

Additional storage spaces are located inside the operating space.



### Quick Response of Operating Control Levers

Only minimal operator's effort is required for precise, safe and productive control.



**Travel Speed Control System (Option)**



← In-Door : Max. Travel Speed 15~17 km/h

← Out Door : Max Travel Speed : 20.1 km/h

■ Photo may include optional equipment



**Adjustable steering wheel**

The steering wheel with horn button can be adjusted by a lever on the left-hand side to improve operators comfortability.



**Easy and safe shift lever**

A single lever on the left side of the steering column gives the operator fast and easy control of travel direction. The engine can only be started in case of neutral position of this lever.



**Multi-function switch lever**

A multi-functional switch lever gives easy access to lights and horn.

# Enhanced safety through high durability!

Safety and durability are priorities in the design of the equipment.



## Strong overhead guard

The safety overhead guard meets ISO 6055 regulations and protects the operator during hazardous jobs.



## Parking Brake

Toggle type parking brake requires less efforts from the operator to set.



## Highly durable split type drive axle

The advanced drive axle always delivers the desired torque to the drive wheels



## Large footstep & Handle

Wide "open" step ensures easy and safe access to the operator's seat



## Expansion bellows

The expansion bellows absorbs vibration and reduces noise generated from the exhaust gas system and extends the life cycle.



## Electrically Monitored Air Filter

An air cleaner sensor alerts the operator of a restricted air filter so allowing replacement before a potential engine damage occurs.





■ Photo may include optional equipment

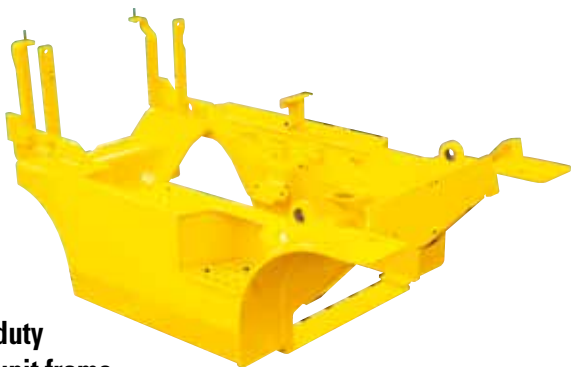

### Heavy duty single unit frame

Heavy duty single unit type frame, designed on the basis of accurate structural analysis, guarantees durability and safety.



### Bright, protected headlights

Bright, protected headlights are positioned for increased visibility in dark environments.



### Rear safety lamp

Rear combination lamps with directional indicators, rear lights and brake lights are positioned for a high level of safety.

# Centralized design for easy service!

An ideal arrangement of components ensures easy access and convenience during maintenance.



## Easy change air cleaner

The air filter is readily accessible for cleaning or replacement.



## Fast Service Access for Daily Fluids Check



## Rotational Battery Installation



## One Touch, No Tool Floor Plate



## Aluminum radiator with superb protection against heat



## Improvement in Maintenance of Electric Parts

Various electric parts are centralized in dash board resulting in effortless troubleshooting.



## Easy Maintenance oil check

The T/M oil level can be checked easily without any disassembly.

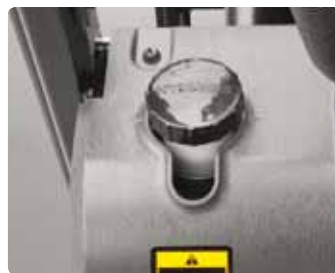

## Brake fluid reservoir

Highly visible and accessible reservoir makes daily inspections a quick and easy job.



## An accessible, compact fuse box for easy inspection

## Mast Specifications

Mast Type	Maximum Fork Height mm	Overall Height (Lowered) mm	Tilt Angle degree		Free Lift (mm)				Load Capacity without Integral Side Shift 500mm LC (kg)			Load Capacity with Integral Side Shift 500mm LC (kg)			Truck Weight Unload (kg)			
			Fwd	Bwd	With Backrest		Without Backrest		Single Tire			Single Tire			Single Tire			
					15L/18L-7M	20L-7M	15L/18L-7M	20L-7M	15L-7M	18L-7M	20L-7M	15L-7M	18L-7M	20L-7M	15L-7M	18L-7M	20L-7M	
2/ Stage limited free lift	V250	2,525	1,755	6	10	145	150	145	150	1,500	1,750	2,000	1,400	1,650	1,890	2,764	2,938	3,085
	V270	2,725	1,855	6	10	145	150	145	150	1,500	1,750	2,000	1,400	1,650	1,890	2,778	2,952	3,099
	V300	3,025	2,005	6	10	145	150	145	150	1,500	1,750	2,000	1,400	1,650	1,890	2,798	2,972	3,119
	*V330	3,325	2,155	6	10	145	150	145	150	1,500	1,750	2,000	1,400	1,650	1,890	2,818	2,992	3,139
	V350	3,525	2,255	6	10	145	150	145	150	1,500	1,750	2,000	1,400	1,650	1,890	2,832	3,006	3,152
	V370	3,725	2,355	6	10	145	150	145	150	1,500	1,750	1,950	1,400	1,650	1,845	2,845	3,019	3,166
	V400	4,025	2,505	6	10	145	150	145	150	1,450	1,735	1,550	1,365	1,635	1,465	2,870	3,044	3,190
	V450	4,525	2,855	6	6	145	150	145	150	1,375	1,650	1,500	1,290	1,550	1,420	2,936	3,110	3,257
V500	5,025	3,105	6	6	145	150	145	150	1,300	1,450	1,000	1,225	1,365	940	2,970	3,144	3,290	
V550	5,525	3,355	6	5	145	150	145	150	1,000	950	750	930	880	690	2,990	3,164	3,311	
2/ Stage full free lift	TF/TS370	3,735	1,805	6	6	798	803	1,299	1,300	1,500	1,750	1,925	1,400	1,650	1,820	2,913	3,087	3,243
	TF/TS400	4,035	1,905	6	6	898	903	1,399	1,400	1,500	1,700	1,875	1,400	1,600	1,775	2,933	3,107	3,263
	TF/TS430	4,335	2,005	6	6	998	1,003	1,499	1,500	1,450	1,700	1,825	1,365	1,600	1,725	2,952	3,126	3,282
	TF/TS450	4,535	2,105	6	6	1,098	1,103	1,599	1,600	1,425	1,635	1,650	1,340	1,540	1,550	2,971	3,145	3,301
	TF/TS470	4,735	2,155	6	6	1,148	1,153	1,649	1,650	1,400	1,450	1,350	1,320	1,365	1,275	2,938	3,157	3,313
	TF/TS500	5,035	2,255	6	6	1,248	1,253	1,749	1,750	1,375	1,400	1,000	1,295	1,320	935	3,002	3,176	3,332
	TF/TS550	5,535	2,455	6	5	1,448	1,453	1,949	1,950	1,050	1,100	750	985	1,030	690	3,040	3,214	3,370
	TF/TS600	6,035	2,655	6	5	1,648	1,653	2,149	2,150	750	750	500	700	700	450	3,112	3,286	3,442
	TF/TS650	6,535	2,855	3	3	1,848	1,853	2,349	2,350	500	500	450	450	450	400	3,157	3,331	3,487
	TF/TS700	7,035	3,055	3	3	2,048	2,053	2,549	2,550	350	250	300	300	200	250	3,193	3,367	3,523

\* TS-Mast : Wide Visible 3 Stage Full Free Lift Mast with 2 Free Lift Cylinders.

## Load Capacity

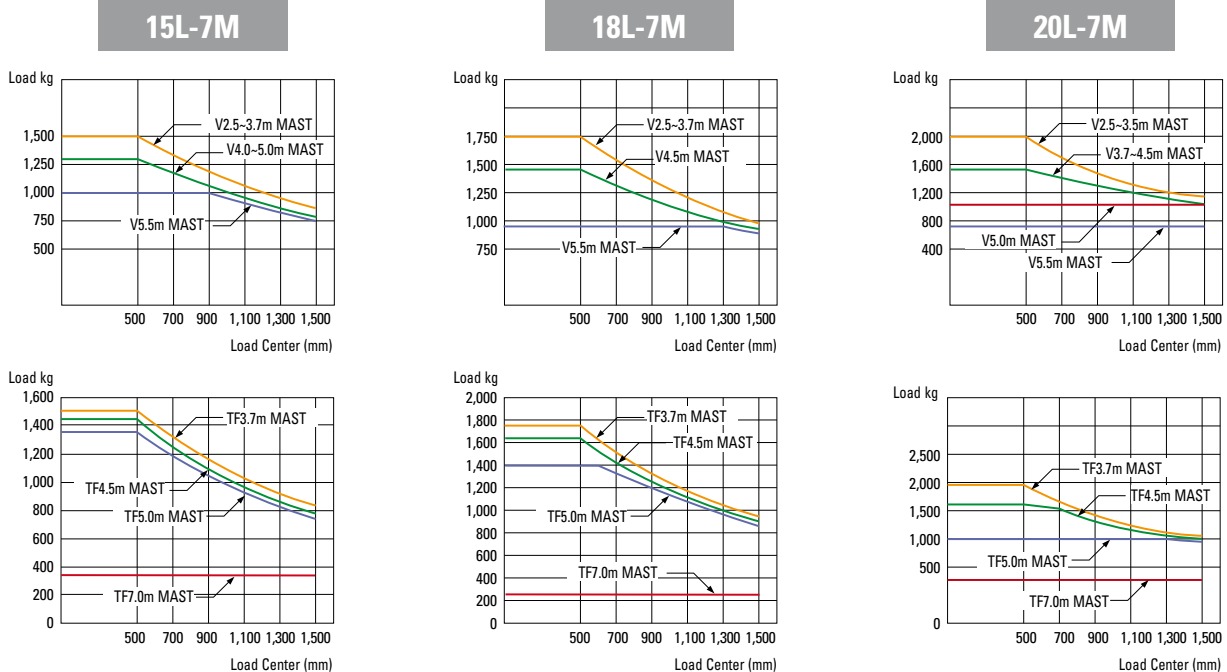

## Optional Items

- **INTEGRAL SIDE SHIFT**
  - **SIDE SHIFT**
  - **FORK**: 750 / 850 / 1,050 / 1,200 / 1,350 / 1,500 mm (15/18L-7M)  
950 / 1,000 / 1,050 / 1,150 / 1,200 / 1,350 / 1,500 mm  
1,600 mm (20L-7M)
  - **OVER SHOE** : 1,300 / 1,500 / 1,700 mm
- **TILTING** : 6/5°, 3/3°, 6/6°
  - **TIRE** : CUSHION, NO-MARKING
  - **SEAT** : POCKET, ARM REST, HIP REST
  - **LPG CLAMP** : SWING OUT, SWING DOWN
  - **M.C.V** : 4-SPOOL
  - **ATTACH PIPING** : 3 SPOOL-PIPING, 4 SPOOL-PIPING
- **MASTER SWITCH**
  - **BEACON LAMP**
  - **HAZARD SWITCH**
  - **WORK LAMP**
  - **TRAVEL SPEED CONTROL SENSOR**

## Dimensions

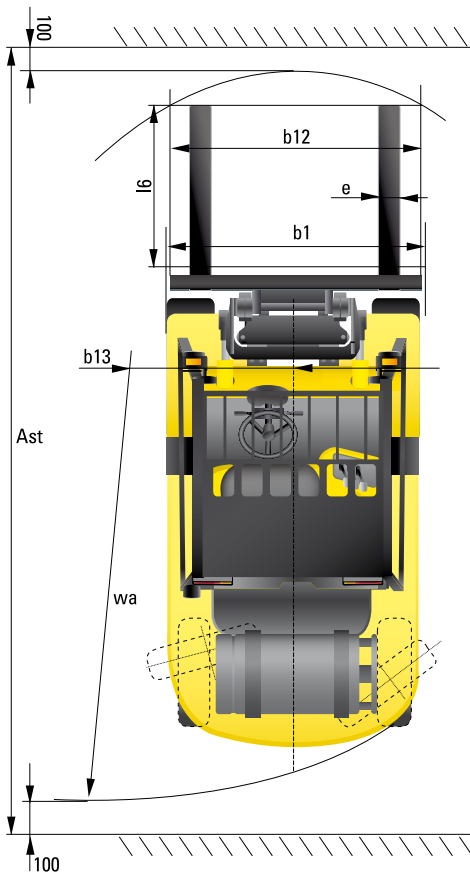
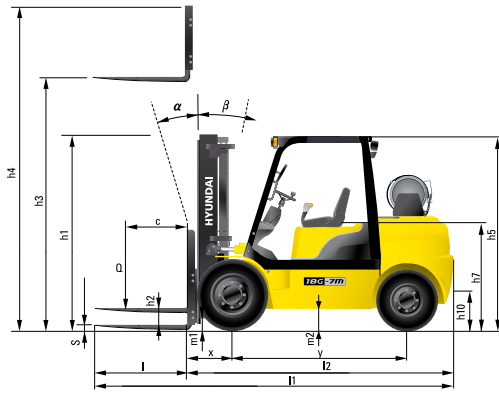

## Specifications

Identification					
1.1	Manufacturer		Hyundai	Hyundai	Hyundai
1.2	Type		15L-7M	18L-7M	20L-7M
1.3	Drive: electric (battery or mains), diesel, petrol, fuel gas, manual		LPG	LPG	LPG
1.4	Type of operation: hand, pedestrian, standing, seated, order-picker		seated	seated	seated
1.5	Load capacity (standard)	Q (kg)	1,500	1,750	2,000
1.6	Load center distance	c (mm)	500	500	500
1.8	Load distance, center of drive axle to forks	x (mm)	393	393	398
1.9	Wheelbase	y (mm)	1,410	1,410	1,410
Weights					
2.1	Service weight	kg	2,690	2,861	3,045
2.2	Axle loading, loaded front/rear	kg	3,640 / 550	4,006 / 605	4,380 / 660
2.3	Axle loading, unloaded front/rear	kg	1,190 / 1,500	1,147 / 1,714	1,106 / 1,939
Wheels, chassis					
3.1	Tires: solid rubber, superelastic, pneumatic, polyurethane		Pneumatic	Pneumatic	Pneumatic
3.2	Tires size, front		6.5 x 10 x 12PR	6.5 x 10 x 12PR	6.5 x 10 x 12PR
3.3	Tires size, rear		5.0 x 8 x 10PR	5.0 x 8 x 10PR	5.0 x 8 x 10PR
3.5	Wheels, number front / rear (X= driven wheels)		2 x / 2	2 x / 2	2 x / 2
3.6	Track width, front	b10 (mm)	890	890	890
3.7	Track width, rear	b11 (mm)	910	910	910
Basic dimensions					
4.1	Mast/fork carriage tilt forward / backward	degrees	6 / 10	6 / 10	6 / 10
4.2	Lowered mast height	h1 (mm)	2,155	2,155	2,155
4.3	Free lift	h2 (mm)	145	145	150
4.4	Lift height	h3 (mm)	3,325	3,325	3,330
4.5	Extended mast height	h4 (mm)	4,332	4,332	4,332
4.7	Overhead load guard (cab) height	h5 (mm)	2,110	2,110	2,110
4.8	Seat height / standing height	h7 (mm)	1,050	1,050	1,050
4.12	Coupling height	h10 (mm)	262	261	258
4.19	Overall length	l1 (mm)	2,233 + ℓ	2,263 + ℓ	2,380 + ℓ
4.20	Length to face of forks	l2 (mm)	2,233	2,263	2,308
4.21	Overall width	b1 (mm)	1,070	1,070	1,070
4.22	Fork dimensions LxWxT	L x E x S (mm)	900 x 100 x 35	900 x 100 x 35	900 x 100 x 40
4.23	Fork carriage ISO 2328, class / type A,B		II / A	II / A	II / A
4.24	Fork carriage width	b12 (mm)	1,004	1,004	1,004
4.31	Ground clearance, loaded, under mast	m1 (mm)	120	120	120
4.32	Ground clearance, centre of wheelbase	m2 (mm)	145	145	145
4.33	Aisle width for pallets 1000 x 1200 crossways (L x W)	Ast (mm)	3,594	3,620	3,661
4.34	Aisle width for pallets 800 x 1200 lengthways (W x L)	Ast (mm)	3,794	3,820	3,861
4.35	Turning radius	Wa (mm)	2,000	2,026	2,061
4.36	Smallest pivot point distance	b13 (mm)	589	589	731
Performance data					
5.1	Travel speed, unloaded	km/h	20.1	20.1	20.1
5.2	Lift speed, loaded/unloaded	mm/s	650 / 680	650 / 680	650 / 680
5.3	Lowering speed, loaded/unloaded	mm/s	500 / 450	500 / 450	500 / 450
5.5	Drawbar pull, loaded	N	1,736	1,746	1,760
5.7	Gradient performance, loaded/unloaded	%	39.7	35.4	33.0
5.10	Service brake		Hydraulic	Hydraulic	Hydraulic
Engine					
6.1	Engine manufacturer / type		L4KB	L4KB	L4KB
6.2	Engine power acc. To ISO 1585	HP	50	50	50
6.3	Rated speed	1/min	2,450	2,450	2,450
6.4	No. of cylinder / cubic capacity	/cm <sup>3</sup>	4 / 2,359	4 / 2,359	4 / 2,359
Other details					
8.2	Type of drive control		Power Shift	Power Shift	Power Shift
8.3	Operating pressure (attachments)	bar	225 / 168	225 / 168	225 / 168
8.4	Hydraulic oil flow (attachments)	ℓ/min	30	30	30
8.5	Sound level at driver's ear according to DIN 12053	db(A)	80	80	80

- \* Standard and optional equipment may vary. Contact your Hyundai dealer for more information. The machine may vary according to international standards.
- \* The photos may include attachments and optional equipment that are not available in your area.
- \* Materials and specifications are subject to change without advance notice.
- \* All imperial measurements rounded off to the nearest pound or inch.

PLEASE CONTACT

**HYUNDAI**  
HEAVY INDUSTRIES EUROPE  
CONSTRUCTION EQUIPMENT

Hyundai Heavy Industries Europe N.V.

VOSSENDAAL 11, 2440 GEEL, BELGIUM TEL: (32) 14-56-2200 FAX: (32) 14-59-3405